

MP953A,B,C,D PNEUMATIC VALVE ACTUATORS

PRODUCT DATA



SPECIFICATIONS

Max. operating pressure	140 kPa
Max. safe air pressure	210 kPa
Air connection	barb fitting for PE tube 6x1 or 1/4" outer diameter

See also Table 2.

DIMENSIONS

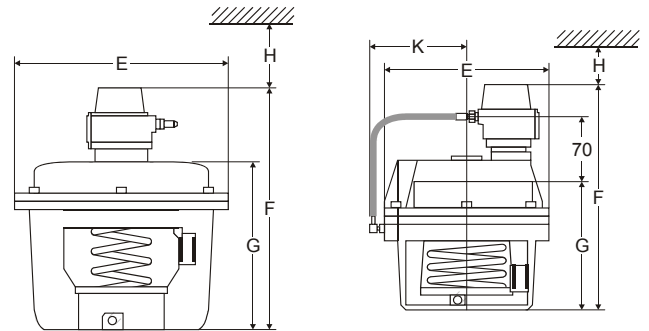

Fig. 1. MP953A,C (left) and MP953B,D

Table 1. Dimensions

Model	EØ	F	G	H	K
MP953A, 125 (5")	130	192	--	120	--
MP953C, 125 (5")		--	120		
MP953A, 200 (8")	210	237	--	140	
MP953C, 200 (8")		--	165		
MP953A, 330 (13")	343	327	--	200	
MP953C, 330 (13")		--	255		
MP953B, 180 (7")	180	242	--	120	107
MP953D, 180 (7")		--	137		--

GENERAL

MP953 Pneumatic Valve Actuators are suitable for use in conjunction with Honeywell valves V5011, V5013, V5015, V5016, V5025, V5049, V5050, V5328, and V5329 to provide proportional control of steam or hot and cold water in HVAC systems.

Table 2. Specifications

order no.	pressure range (kPa)	adjustable start point	positioner	diaphragm Ø	stroke	stem action	max. operating temperature
MP953A5005	34.5 or 69	20.7 to 69	yes	125 mm (5")	20	extends	70 °C
MP953A5039				200 mm (8")			
MP953A5054				330 mm (13")	38		
MP953B5003				180 mm (7")		retracts	
MP953C5001	13.8 to 48.3	--	no	125 mm (5")	20	extends	120 °C
MP953C5019	55.2 to 82.8						
MP953C5027	27.6 to 75.9						
MP953C5068	13.8 to 48.3			200 mm (8")			
MP953C5076	55.2 to 82.8						
MP953C5084	27.6 to 75.9			330 mm (13")			
MP953C5142	13.8 to 48.3						
MP953C5159	27.6 to 75.9						
MP953D5009	55.2 to 82.8			180 mm (7")	20	retracts	
MP953D5025	27.6 to 75.9						

FEATURES

- Rolling diaphragm for long life and low hysteresis
- Easily attached to valve assembly
- May be installed after valve piping
- Slide lock feature permits simple engagement to valve stem
- Models with positive-positioning relay available

ACCESSORIES

Extension Yokes

The extension yoke (see also Fig. 7) provides for extra air circulation and less conduction of heat from the valve body to the pneumatic actuator.

Recommended if the medium temperature in the valve body is in the range of from 150 to 220 °C.

Table 3. Extension yokes

part no.	applied to valves		
43161276-001	V5049A	DN 15...65	PN 25/40
	V5050A	DN 15...80	
	V5025A	DN 15...80	PN 25
	V5016A	DN 15...80	PN 16
	V5328A	DN 40...80	
	V5329A		
	V5329C	DN 40...80	PN 6
43297431-001	V5011R,S	DN 15...32	PN 16
	V5013R,E		
	V5328A		
	V5329A		
	V5329C		

Repair Kit Diaphragm

Table 4. Repair kit diaphragms

part no.	model
R43312760-001	MP953A,C 125 (5")
R43161319-001	MP953A,C 200 (8")
R43161320-001	MP953A,C 330 (13")
R43180626-001 (diaphragm. a. sleeve)	MP953B,D 180 (7")
R43161322-001 (sleeve)	MP953B,D 180 (7")

TYPICAL OPERATION

In a direct-acting (normally-open valve) system, an increase in control air pressure will force the actuator diaphragm and cup downward, forcing the valve stem down to proportionally close off the flow through the valve.

Operators without the positive positioner have branch line pressure applied to the diaphragm. Operators with positive positioners have up to full main air pressure applied to the diaphragm to ensure that the valve is positioned proportionally to the branch line pressure.

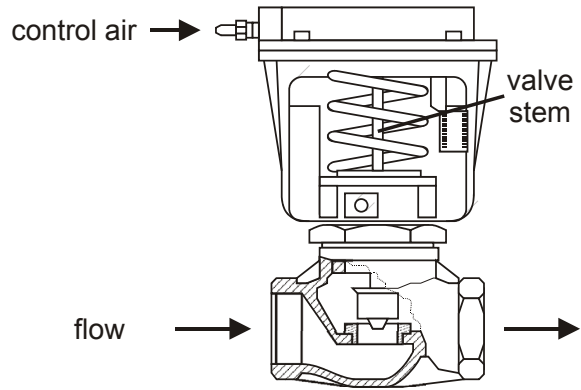

Fig. 2. Typical operation

INSTALLATION

General

Ensure that the actuator has the correct size and travel to match the valve body. Refer to the corresponding valve product literature.

Mounting the MP953A,C (Size 5")

1. Pull the valve stem up.
2. Position the stem-locking slide so that the large hole is in view (see also Fig. 3).
3. Set the actuator on the valve bonnet. Ensure that the stem button passes through the hole in the stem-locking slide and that the actuator is down flush on the shoulder of the valve bonnet.
4. Rotate the actuator on the valve bonnet to the desired position and tighten both actuator set screws.
5. Apply air pressure until the diaphragm cup contacts the stem button and secure the stem button with the stem-locking slide.

Mounting the MP953A,C (Size 8" and 13")

1. If converting from smaller-size actuator, remove the actuator by following, in reverse order, the steps outlined in section "Mounting the MP953A,C (Size 5)".
2. Remove the stem button (see also Fig. 5).
3. Screw the stem button on the (single or double) stem extension until it bottoms.
4. Screw the stem extension on the stem until it bottoms (flats or locking-pin hole provided).
5. Rotate the stem extension as required to adjust dimension "Y" as per Table 5 to the value listed, then lock the stem extension in place by tightening the hex nut.

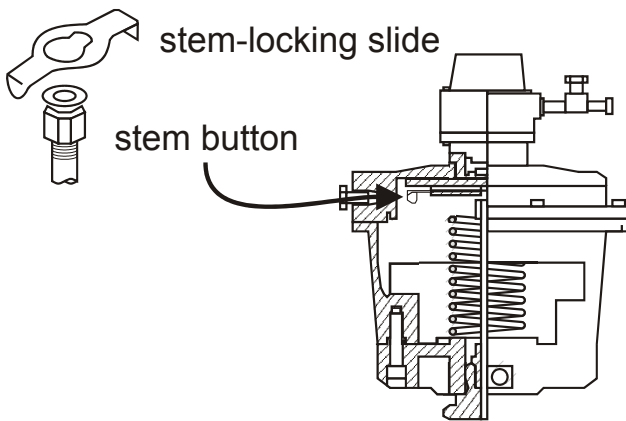

Fig. 3. Stem-locking slide

4. Turn the stem connector screw by its screw-slot counterclockwise to back out the stem button until the actuator is in contact with the shoulder of the stem button.
5. Push the actuator onto the valve bonnet and hold it firmly in place; tighten the two set screws
6. Load the stem by turning the stem connector screw clockwise by its screw slot.
 - a) On a straight-through valve (position 1), turn the stem connector screw until a clearance A of approx. 3 mm (1/8") exists between the spring and the actuator spider.
 - b) On a three-way valve, a clearance A and B of approx. 1.5 mm each is required at both ends of the stroke to permit proper close-off. If there is no air on the actuator, adjust the A clearance approx. 1.5 mm and recheck the B clearance when air is available.
7. If clearances A and B cannot be adjusted following the procedure outlined above, check the stem height "y" and adjust, if necessary.

Table 5. Dimensions Y, in mm

	actuator size			action to open
	5", 7"	8"	13"	
valve size	DN	DN	DN	
valve series	15...80 Y ₁	15...80 Y ₂	100...150 Y ₃	
V5016A				↑
V5025A	89	133	190	
V5328A				
V5011R,S	89	133	--	↑
V5013R,E	107	151	--	
V5015A	--	--	227	↓
V5050A				
V5329A,C	107	151	--	
valve size	DN	DN	DN	action to open
valve series	15...65	15...65	80...100	
V5049A	89	133	190	↑

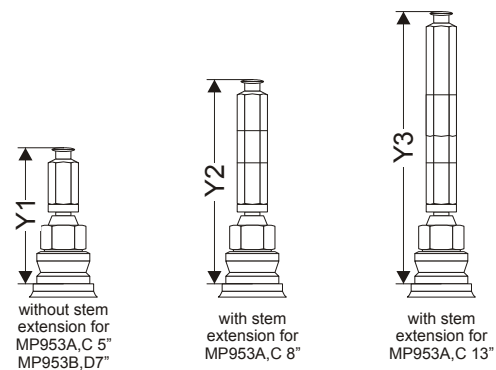

Fig. 5. Stem extensions

Mounting the MP953B,D

1. Pull the valve stem up.
2. Attach the stem connector screw to stem button (Fig. 4).
3. Place the actuator on the valve without pushing the stem down.

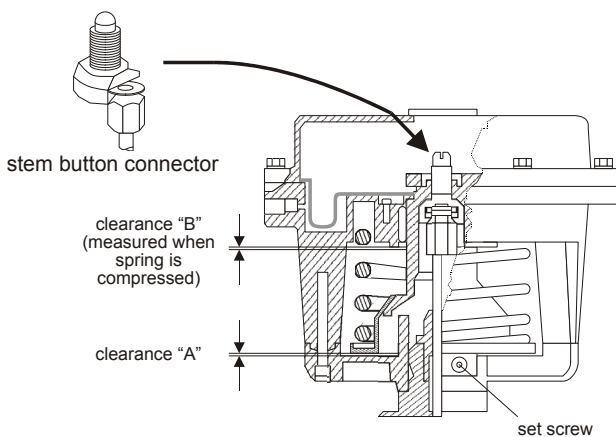
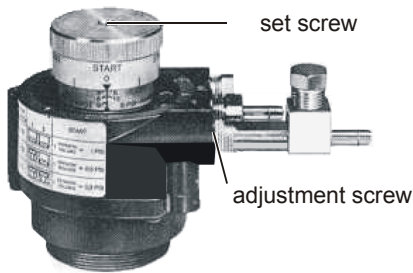

Fig. 4. Attaching the stem connector screw

ADJUSTMENTS

NOTE: Adjustments are necessary only for the GRADUTROL-Relay used with the MP953A, B.

The range is adjusted using six adjustment screws (see also Fig. 6). Note label on body of GRADUTROL-Relay. All devices are factory-set for 35 kPa range. This point is adjusted by turning the adjustment knob. The graduations of the external calibration scale on the knob present various values within the different ranges. All devices are factory-set for 35 kPa start point. After completing the adjustment procedure, do not change the position of GRADUTROL-Relay (with respect to the actuator).





operating range	range adjustment	start point adjustment
70 kPa (10 psi)	ALL screws "1" and "2" tightened.	 One graduation of scale on the start point adjustment knob represents a start point change of 7 kPa. One complete turn of the start point adjustment knob represents a start point change of 7 kPa.
35 kPa (5 psi)	Three screws "1" backed off to friction stop.	 One graduation of scale on the start point adjustment knob represents a start point change of 3.5 kPa. Two complete turns of the start point adjustment knob represent a start point change of 70 kPa.
21 kPa (3 psi)	ALL screws "1" and "2" backed off to friction stop.	 One graduation of scale on the start point adjustment knob represents a start point change of 2 kPa. Three complete turns of the start point adjustment knob represent a start point change of 62 kPa (note auxiliary scale).

Fig. 6. Adjustments of ranges and start points

Adjustment Check

1. Install a gauge in the pilot air line (P).
2. Adjust the set screw (see Fig. 6) so that travel just begins.
3. Increase pilot pressure (P) until travel is complete. If the adjustment is correct, the gauge should read this pressure within ± 5 kPa of the start point pressure plus the range setting.

EXAMPLE: Range setting 35 kPa start point setting 21 kPa. The gauge should then read 56 ± 5 kPa after the travel is completed.

4. If the measured pressure should not be within the permissible variation, fine adjustments must be done (if necessary) using the start point adjustment knob.

MOUNTING WITH EXTENSION YOKE

For working temperatures of 150 to 220 °C (300 to 425 °F), use of an extension yoke is mandatory for the MP953A,C (5" and 8") and the MP953B,D actuators to protect the diaphragm against excessive heat. Screw the stem extension (for the 5" size) onto the stem, with the stem either pulled out or pushed in (see Fig. 7), and adjust dimension "y" to the value listed in Table 6. Lock stem extension into place by tightening the hex nut, and attach the yoke.

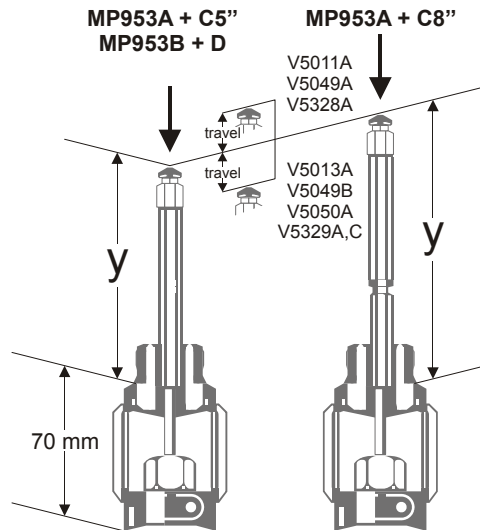

Fig. 7. Extension yoke

Table 6. Mounting actuators with extension yoke

actuator	"y" (mm)	valve
MP953A,C, 5"	89	V5011R,S, V5328A, V5016A, V5025A, V5049A
MP953B,D	107	V5013R,E, V5329A,C, V5050A
MP953A,C, 8"	133	V5011R,S, V5328A, V5016A, V5025A, V5049A
	151	V5013R,E, V5329A,C, V5050A